

Spectrum Handoff Mechanism in Cognitive Radio Networks using Fuzzy Logic

Prudhvi Raj Metti, K. Rushendra Babu, Sumit Kumar

Abstract— In the wireless networks, there is the problem of spectrum inefficiency and spectrum scarcity. The above problems can be solved by introducing the cognitive radio (CR) technology. Cognitive radio can be simply called as intelligent radio that self-detects the available channels in the wireless spectrum. The CR networks have the functionalities such as spectrum sharing, spectrum sensing, spectrum mobility and spectrum management. In this paper, we discuss the spectrum mobility in the CR networks (CRN), Spectrum handoff mechanism using fuzzy logic. For the channel representation, it is essential to discuss the artificial neural networks (ANN) concept. In this paper we addressed the fuzzy logic concept to solve the spectrum handoff issues in CR network.

Keywords— Cognitive radio, Spectrum sensing, Spectrum handoff, Fuzzy logic, Artificial Neural Network (ANN).

1. INTRODUCTION

In the recent times, cognitive radio technology is prominently increasing its need in the field of communications. The concept “cognitive radio” was first proposed by Joseph Mitola III in a seminar at KTH, Stockholm in 1998 and published an article in 1999. CR can detect the available channel in its radio environment. It is also called “intelligent radio”. It has intelligent functionalities such as spectrum sharing, spectrum sensing, spectrum mobility and spectrum management. In this section, we discuss the functionality of spectrum mobility.

- *Mr. Prudhvi Raj Metti is currently pursuing M.Tech in Digital Electronics and Communication Systems, Gudlavalleru Engineering College affiliated to JNTU, Kakinada, India. Email :prdhv.raj1@gmail.com*
- *Mr. K. Rushendra Babu is currently working as Assistant professor in the Department of Electronics and Communications, Gudlavalleru Engineering college, Gudlavalleru, India, Email :educationdetails.krb@gmail.com*
- *Mr. sumit kumar is currently working as Junior research scientist in Signal Processing and Communication Research Centre, IIIT, Hyderabad, India. Email :sumitstop@gmail.com*

Spectrum mobility is defined as the event where secondary user (SU) switches to the better spectrum because of arrival of licensed user. Cognitive user can also be called as secondary user. When licensed user arrives, SU should shift from current channel to another vacant, best channel for the seamless communication because licensed user has more priority. The licensed user can be also called as primary user (PU). SU communication is often disrupted in the highly dynamic environments. Hence there is need to

introduce spectrum mobility in the cognitive radio networks (CRN) to enable seamless SU data transmission. The SU uses the spectrum handoff concept for transferring to the vacant channel from an ongoing communication channel. There are multiple handoff strategies which we have discussed in the upcoming sections. In section 2, we discuss the spectrum handoff and when it is going to be executed. In section 2.1, we discuss the different handoff strategies and their performance. In section 3, it is given a brief note on the literature survey. Our proposed work using fuzzy logic and ANN is discussed in detail in section 4.

2. SPECTRUM HANDOFF

When PU arrive the channel then SU should switch to the other vacant channel for the seamless communication. This process is called spectrum handoff. In the licensed channel, PU is given more priority over the SU. SU can communicate in the channel whenever there is absence of PU. It can also communicate in the same channel until the SU doesn't cause interference to PU. Hence SU is often disrupted in the highly dynamic environments. Thus there is a need to introduce the spectrum mobility. This enables seamless SU data transmission. The main task of the spectrum mobility in cognitive radio network (CRN) is to perform continuous channel switch over while sustaining performance of ongoing secondary user (SU) communication. In order to do this, spectrum mobility is classified into two processes: spectrum handoff and connection management [1].

Spectrum handoff process naturally causes additional latency to SU communication that effects SU performance.

In [1] authors mentioned that in order to avoid the handoff delay, connection management adjusts and processes protocol stack parameters according to the current situation. There are two primary user (PU) associated events that can initiate spectrum handoff in CRN. First, PU appearance in the licensed channel essentially makes SU to establish handoff. Second, spectrum handoff can happen because of SU user mobility. In the second case, when CR user moves spatially, it may happen transmission coverage of the cognitive user overlaps with a licensed user currently using same channel.

Spectrum handoff can be explained as a cyclic process. It has two phases: Evaluation phase and Link maintenance phase. In the evaluation phase, Cognitive user observes the situation and analyses whether handoff triggering incident shall take place or not. Once SU chooses to perform spectrum handoff, it enters link maintenance phase. In this phase, cognitive user hand over the channel to the licensed user and maintains data transmission over another available channel. Finally SU vacate the link maintenance phase and then continues cycle.

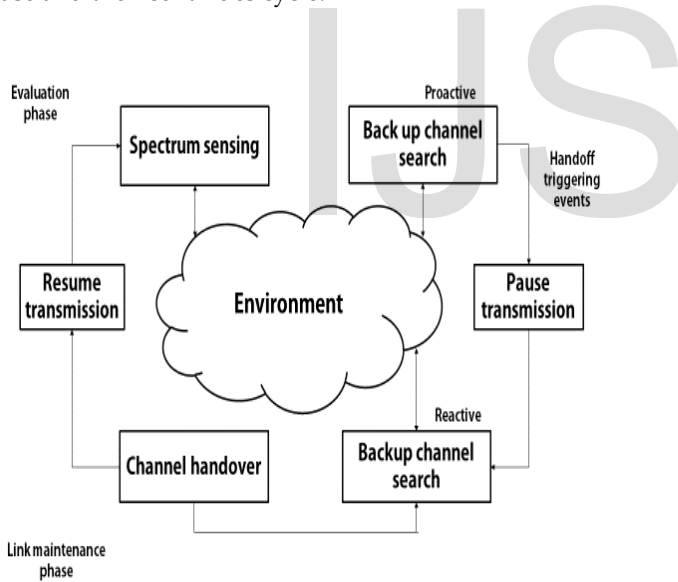

Figure 1. Spectrum handoff process (ref)

2.1. Spectrum handoff strategies

Handoff strategies can be broadly classified into four types namely Non handoff, Pure reactive, Pure proactive and Hybrid handoff strategy [1]. In Non handoff strategy, SU remains in the same channel and will be idle till the channel becomes free again. In this approach waiting latency is more because SU should remain idle till PU vacates the channel. In pure reactive handoff strategy, once a handoff triggering event happens it performs the spectrum sensing

to find backup target channel. In other words, both handoff action and backup channel selection are performed reactively after triggering event happens. Advantage of this approach is getting accurate channel selection. SU performs the spectrum sensing after detecting the handoff event, an inherent delay is associated with this handoff process

In the proactive approach, SU performs the spectrum sensing before handoff triggering event happens. Based on PU traffic model, SU can estimate the PU arrival and can evacuate the channel beforehand. In this approach both channel selection and handoff are performed proactively before the handoff triggering happens. Advantages of this approach are handoff latency can be reduced and multiple spectrum handoffs can be reduced because everything is planned in advance. Drawback of this proactive approach is that the channel remain obsolete i.e. sometimes the channel can be occupied by other user during handoff. Hybrid handoff strategy is the combination of pure and proactive handoff strategies. It performs proactive spectrum sensing and reactive handoff action. Even though we choose hybrid handoff strategy the latency is more compared to proactive strategy.

3. PREVIOUS WORK

Authors in [6] attempt the wide range study on the performance of three vertical handoff algorithms. They are SAM (Simple additive weighting), TOPSIS (Technique for order preference by similarity to ideal solution) and MDP (Markov decision process). Analytical and simulation tools (ns.2.2.9) are used to calculate and compare projected total QoS submissions in the mean duration of service underneath different state transition probability distributions. It is observed that TOPSIS achieve the best performance in spite of MDP's with optimal policy.

Authors in [5] propose a spectrum handoff based on mobility, QoS and priority. The system mostly focuses on mobility of SU. A novel resource usability constraint is used to prioritize some significant situation in handoff. This paper implements the work with fuzzy logic and the neural network for the successful handoff. Using fuzzy controller helps the approximated values of parameters as per requirement. Use of artificial neural network helps to get precision of about 100% in handoff decision. The system is limited for seven cell cluster; and it can be extended the same for more cells cluster. In the proposed work we use the fuzzy logic for support of taking the decision about handover and ANN is used for the channel prediction

Authors in [2] propose a novel proactive spectrum handoff approach based on time estimation to reduce communication interruptions to PU and increase channel utilization. SU uses past channel history to maintain an estimation vector of the channel remaining idle period and make predictions on future spectrum availability and then schedule the channel usage in advance. This proposes a smart channel choice and switching algorithm to perform above approach. Simulation results show that approach can considerably reduce communication disruptions to primary users up to 32% and increase overall channel efficiency by about 7-18%. This approach increases the average channel selection by SUs and reduces the disruptions to the PU. The proactive spectrum handoff decision based on channel prediction to reduce the handoff delay concept is used in our proposed work. We also used the past channel history in our proposed work. Based on this idea we can predict the future channel availability

Authors in [3] present a new approach for handoff management including a spectrum sharing solution and spectrum handoff decision method. Proposal depends on Multi Agent Negotiation to allow CR terminals switching towards the better available spectrum band. The main contributions are first, it will make spectrum sharing allowing spectrum use to achieve up to 90%. Second, it ensures soft and immediate handoff. Third, minimizes the handoff blocking rate which is necessary to evade service disturbances during user mobility. Finally it generates high usefulness for CR users. This approach gives efficient handoff compared to the solutions that do not concern negotiation process it is confirmed that the current approach improves the system performance. The paper didn't give the impact of speed and model of cognitive radio users on the system performance.

Author in [4] proposed a multi cell spectrum handoff scheme as a supplement of reporting of underlay network. Simple additive weights decision algorithm with dynamic weights (SAW-DW) in spectrum handoff is used to select optimal target cells for SU to avoid service disrupt when SU go beyond underlay constraint. Theoretical algorithm and simulation shows that the probability of handoff failure and service interrupts of SU and improves quality of service. This paper doesn't give the idea of dynamic threshold. By making use of the above idea, we can decrease the probability of handoff failure. But we are not using this idea in our proposed work. One may extend this work for efficient handoff without any failure.

4. PROPOSED WORK

We propose a pure proactive handoff strategy that uses control channel list. SU uses proactive spectrum sensing and proactive handoff action. By this method we can predict the PU arrival so that SU can leave the channel in advance. In this paper, we can take accurate decision using the fuzzy logic approach and we can predict the channel availability using Artificial Neural Network (ANN) technique.

4.1. Fuzzy based handover decision

This section gives a brief overview of fuzzy logic. The word *fuzzy* means unclear, vague. Fuzzy logic is a simple mathematical tool that is useful in cognitive radio networks for taking decision whether handoff is required or not. Fuzzy logic controller consists of the components fuzzy rule base, knowledge base, fuzzifier and defuzzifier. Fuzzy logic controller has given a crisp data, it is fuzzified in the fuzzifier and it is defuzzified in the defuzzifier. Fuzzification determines the inputs percentage of membership in the overlapping sets. Defuzzification combines all fuzzy actions into a single fuzzy action and transform single fuzzy action into a crisp data output. Centre of area is the defuzzification method used in this approach.

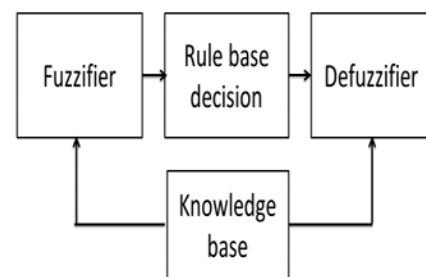

Figure 2. Architecture of FLC (ref)

A certain degree to a specific membership function is consisted with fuzzy logic. The membership degree is specified in the range between 0 and 1. The extreme values of range are 0 and 1. A linguistic variable is commonly decomposed into set of linguistic terms. For example, speed (s) is the linguistic variable. Then $X(s) = \{\text{fast, medium fast,}$

slow, very slow}. Here fast, slow etc. are the linguistic terms.

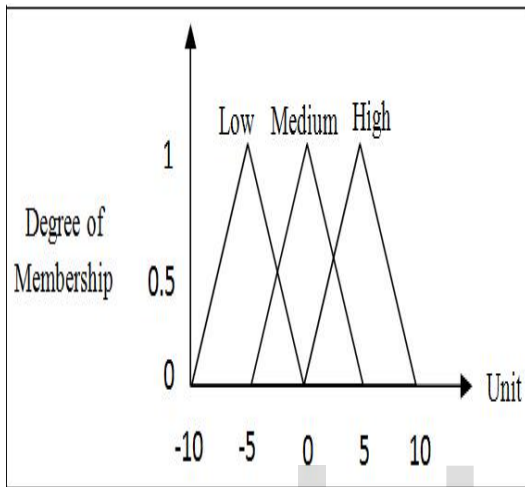

Figure 3. Low, Medium and High membership functions (ref)

In this paper, inputs such as bit error rate (BER) of SU and bit error rate of PU and outputs such as HO (indicates whether handoff is required or not) and PSU decrement (power decrement of SU). Output PSU indicates whether power decrement of SU is required or not. After the giving the inputs fuzzy controller decides whether handover required or not and PSU decrement is required or not. On the assistance of fuzzy logic SU takes decision depending on the fuzzy rules that are framed in the fuzzy rule base. After the successful decision, SU compares the transmission power levels with PU, if SU decrements his power level thereby it doesn't causes the interference to PU, he can communicate in the same channel or if PU faces the interference due to power level of SU then SU should take handover. Next task for cognitive radio user is spectrum sensing which maintains practical channel data availability record. CR user jumps to another free channels depending upon the BER's of SU and PU. Based on the proactive handoff strategy in cognitive radio networks, SU predicts the PU arrival, maintains the data base of channel availability at instant of decision. When the licensed user arrives, SU takes the decision of handover and serves in best available channel.

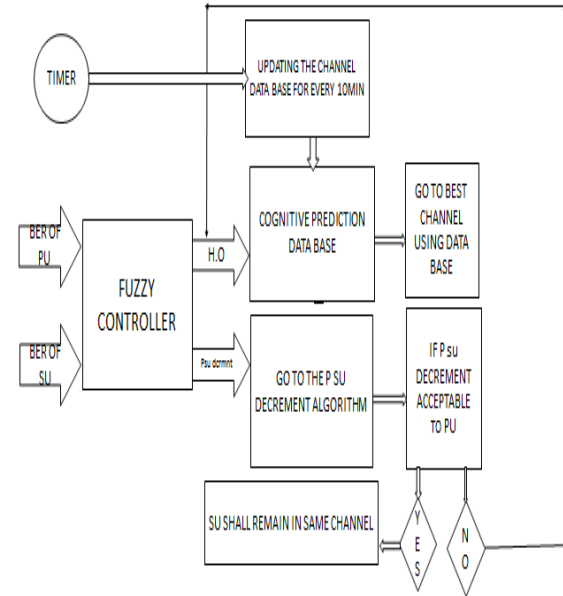

Figure 4. Block diagram of the proposed work

4.2. Fuzzy Rules

Fuzzy rules are framed to control the output. These are framed on the basis of simple IF AND THEN rules. One of the rule that can be framed from the below table is "If BER of PU is *low* and BER of SU is *low* then handover is not required and PSU decrement is not required

Inputs		Outputs	
BER of PU	BER of SU	Handover	SU Power Decrement
Low	Low	Not Required	Not Required
Low	High	Required	Not Required
Low	Medium	Not Required	Not Required
High	Low	Required	Not Required
High	High	Required	Not Required
High	Medium	Required	Not Required
Medium	Low	Not Required	Not Required
Medium	High	Required	Not Required
Medium	Medium	Not Required	Required

4.3. Channel Selection

It is the most important task during the handover. SU confronts the challenge of taking the decision of best available channel. Channel characteristics are channel availability, channel availability at the time of handover,

probability of channel being available in the future. Poor channel selection may cause severe degradation on the performance of SU and may cause multiple spectrum handoffs. In our proposed work SU uses control channel list and communicates over these channels for channel availability and channel occupancy information. We use the predicting the channel availability method in the proposed work. By using this method we can reduce the sensing delay during spectrum handoff and also SU can get the accurate best available channel. SU also know that how much time the channel is available for the communication. The channel availability information for the SU is updated for every 10 minutes using the timer. Referring to the above scenario, SU can take accurate decision, resulting in most appropriate target channel selection. Also handoff latency is lesser when compared to conventional full sensing methods in cognitive radio network.

Table 2. Availability of channels

Time (Sec)	1	2	3	4	5	6	7	8	9	10
Channel 1	11	12	10	13	12	16	74	96	74	45
Channel 2	19	45	12	42	48	74	23	78	41	87
Channel 3	66	78	74	84	78	41	85	12	19	78
Channel 4	46	92	12	23	10	32	87	89	81	65
Channel 5	78	14	96	89	74	56	11	10	16	18

Example showing percentage of PU data traffic in channels

In the table 2, best channel indicates that channel having lowest percentage of PU data traffic in channel. We can see that up to 6sec time, the channel 1 is best for SU, later channel 5 is better. The basic idea implemented in this part is prediction followed by sensing [8].

5. SIMULATION RESULTS

Representation of the fuzzy rules, inputs and outputs are shown in Fig 5.

In Fig 5. bit error rate of PU is medium (indicated in yellow color in rule 8) and bit error rate of SU is medium (indicated in yellow color in rule 8, column 2) and outputs show that SU power decrement is required (indicated in blue color in rule 8, column 3) and handoff is not required(

indicated in blue color in rule 8, column 4). In the same Fig 5 . of rule 7 and column 3, the outputs shows that power decrement of SU is not required(indicated in white color) and handoff is also not required(indicated in white color, column 4).

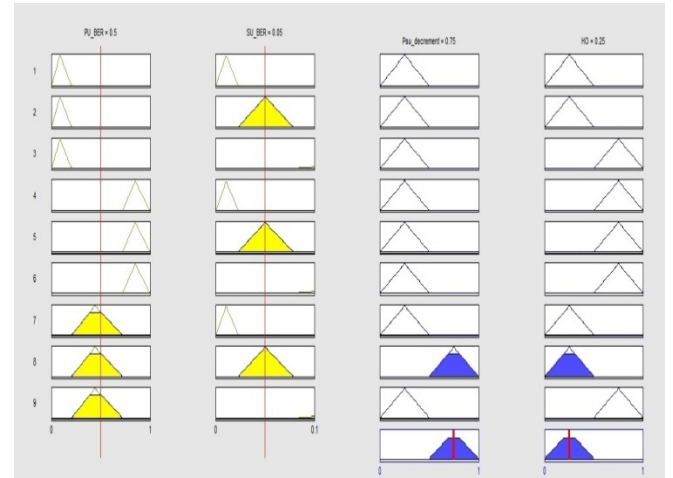

Figure 5. Representation of Fuzzy inputs and outputs (Rules view in Matlab)

Channel availability when trained in artificial neural network (ANN) using time series tool, we get the prediction of availability of PU in channel In Fig 6. Initially there is no presence of PU in the channel (indicated up to the vertical line shown in error and later PU arrived in the channel.

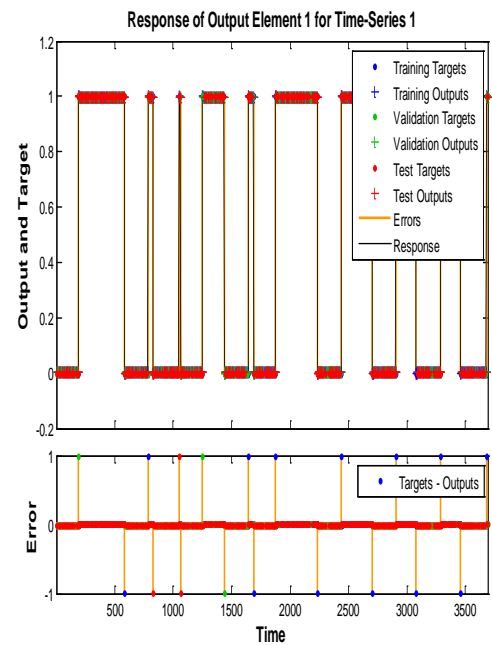

Figure 6. Representation of PU data traffic in a channel

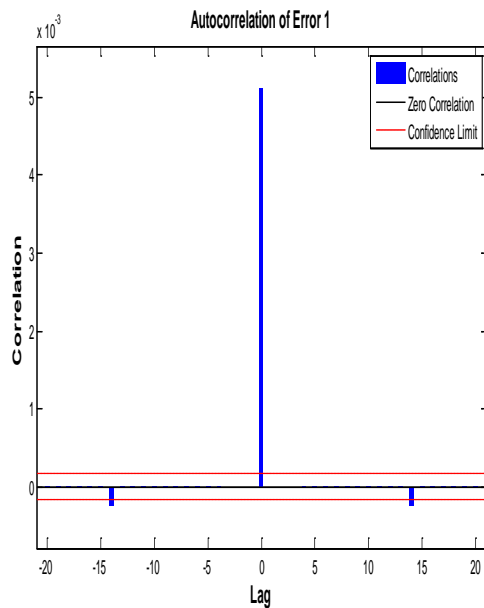

Figure 7. Plot of error auto correlation

Peak in the middle of the auto correlation plot indicates that error is almost zero.

6. CONCLUSION

Spectrum handoff plays a major role in the spectrum mobility. The mechanism we discussed in this paper gives the idea of spectrum handoff in cognitive radio networks and also says which channel is best for CR user. In this paper, we discussed the spectrum handoff issues. We use fuzzy logic concept for optimal handoff decision. It gives the clear idea whether handoff is required or not. ANN concept is used for the representation of channel and data is trained in the network for more number of times to get accurate channel selection. We used prediction followed by sensing to get accurate channel selection and SU switches to best channel using the control channel list. Since we are using proactive approach, the latency will be less compared to full sensing methods and handoff strategies which we are discussed above. The approach gives the perfect data base of channels by prediction method. One may extend this work to get less probability of handoff failure.

ACKNOWLEDGEMENT

I am thankful to Mr. K. Sumit Kumar, Junior Research Scientist in IIIT, Hyderabad and Mr. K. Rushendra Babu, Assistant Professor, ECE, Gudlavalleru Engineering

College, Gudlavalleru. I am feeling glad for your kind support throughout the research Work. I express deep sense of gratitude to Dr. M. Kama Raju, HOD, ECE, Gudlavalleru Engineering college.

7. REFERENCES

- [1] Christian, I; Moh, S.; Ilyong Chung; Jinyi Lee, "Spectrum mobility in cognitive radio networks," *Communications Magazine, IEEE*, vol.50, no.6, pp.114,121, June 2012 doi: 10.1109/MCOM.2012.6211495.
- [2] Lu Li; YanmingShen; Keqiu Li; Kai Lin, "TPSH: "A Novel Spectrum Handoff Approach Based on Time Estimation in Dynamic spectrum networks", " *Computational Science and Engineering (CSE), 2011 IEEE 14th International Conference on*, vol., no., pp.345,350, 24-26 Aug. 2011.
- [3] Trigui, E.; Esseghir, M.; Boulahia, L.M., "Spectrum handoff algorithm for mobile cognitive radio users based on agents' negotiation," *Wireless and Mobile Computing, Networking and Communications (WiMob), 2013 IEEE 9th International Conference on*, vol., no., pp.750,756, 7-9 Oct. 2013.
- [4] XianzhongXie; Guang Yang; Bin Ma, "Spectrum handoff decision algorithm with dynamic weights in cognitive radio networks," *Mobile Congress (GMC), 2011 Global*, vol., no., pp.1,6, 17-18 Oct. 2011 doi: 10.1109/GMC.2011.6103935
- [5] Potdar, S.M.; Patil, K.P., "Efficient spectrum handoff in CR network based on mobility, QoS and priority using fuzzy logic and neural network," *Contemporary Computing (IC3), 2013 Sixth International Conference on*, vol., no., pp.53,58, 8-10 Aug. 2013
- [6] Mardeni, R.; Anuar, K.; Hafidzoh, M.; Alias, M.Y.; Mohamad, H.; Ramli, N., "Efficient handover algorithm using fuzzy logic underlay power sharing for cognitive radio wireless network," *Wireless Technology and Applications (ISWTA), 2013 IEEE Symposium on*, vol., no., pp.53,56, 22-25 Sept. 2013
- [7] Sivanandam, S. N., SaiSumathi, and S. N. Deepa. *Introduction to fuzzy logic using MATLAB*. Vol. 1. Berlin: Springer, 2007.
- [8] K. Sumit kumar, "Efficient Spectrum Sensing/Monitoring Methods and Testbed Development for Cognitive Radio based WSN",

2014 Wireless Innovation Forum Conference on
Communications Technologies and Software
Defined Radio (SDR-WInnComm 2014).

IJSER